

CAD FILE:

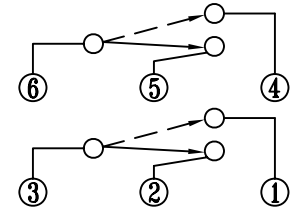

SCHMATIC

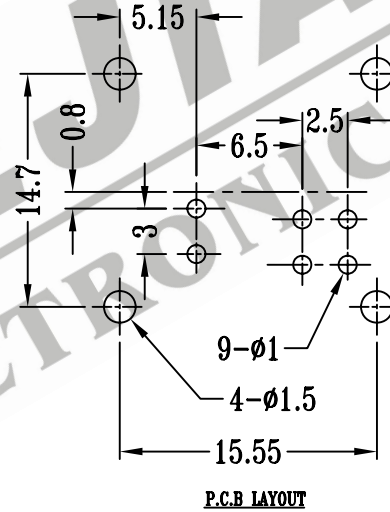
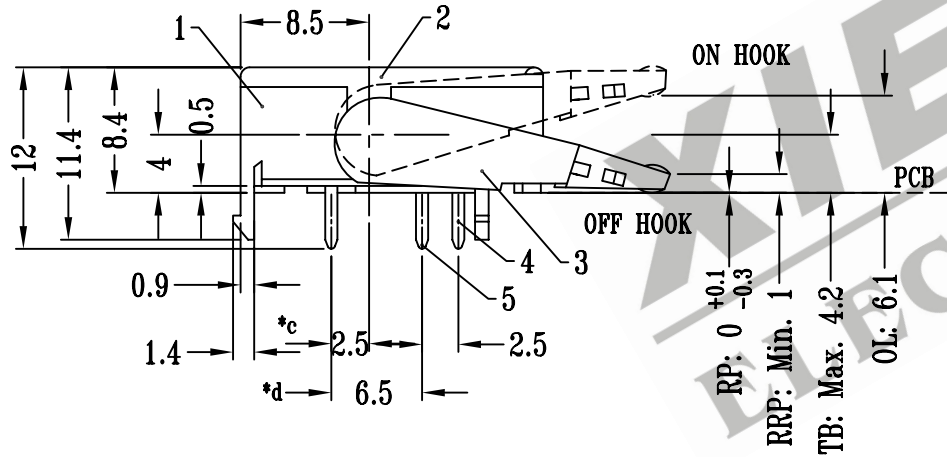
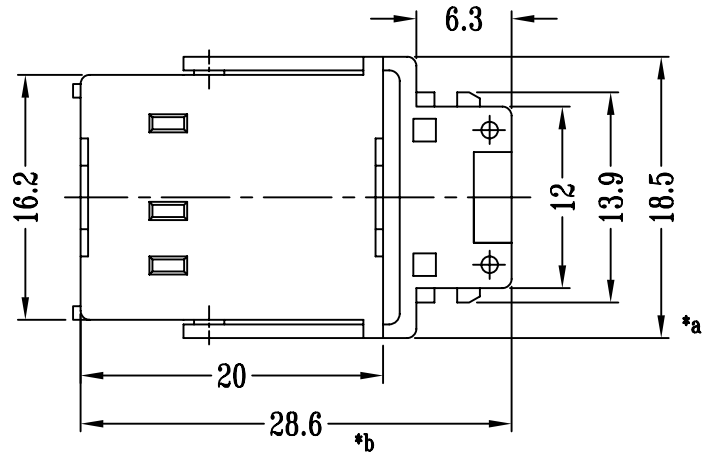
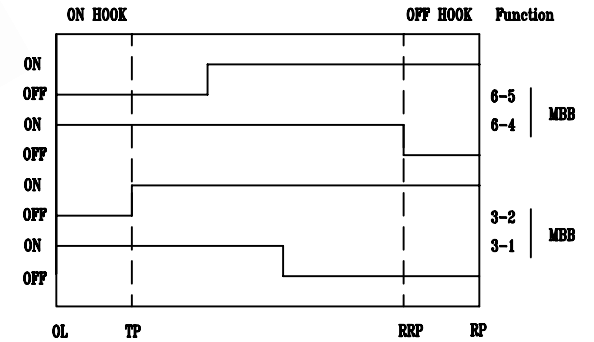

FEATURES

OPERATING FORCE: 60±20 gf

注:带*表示关键尺寸(7个)

8	SPRING	30# SUS	1	TEMPER	TOLERANCE UNLESS SPECIFIED	SHENZHEN XIEJIA ELECTRONICS CO.,LTD.				
7	CONTACT POINT	BRASS	2	PLATING Au OVER Ni						
6	TERMINAL	Ti-Cu STRIP	2	Sn PLATED	WITHIN : 1.5±0.1mm	ISSUE	DATE	DESCRIPTIONS OF REVISION	APPD.	
5	TERMINAL	BRASS STRIP	2	Sn PLATED	OVER : 1.5±0.2mm					
4	TERMINAL	BRASS STRIP	2	Sn PLATED	TITLE : HOOK SWITCH		UNIT : mm	DRWG NO.: XJ-DR-HS22L06-00		
3	KNOB	NYLON+30%GLASS	1	WHITE	MODEL: HS-22L06		SCALE: 1:1	DWN.	ZHOUYU	2004-12-5
2	COVER	PBT+30%GLASS	1	BLACK	ALL MATERIALS MUST BE COMPLIANT TO ROHS			CHK'D	FANGYING	2004-12-5
1	CASE	PBT+30%GLASS	1	BLACK				APPD.	KANGXINAN	2004-12-5
NO.	PARTS	MATERIALS	Q'TY	FINISH						